

Heat Network Solutions



altecnic.co.uk

altecnic
CALEFFI group

Authentic Accredited Altecnic



As the UK's leading manufacturer and supplier of superior plumbing equipment, Altecnic is committed to significantly investing in new technology to bring innovative products to market. As part of the global Caleffi organisation, Altecnic offers a comprehensive range of internationally accredited plumbing and heating products which meet all current UK and European standards. The specialist renewables division provides professional installers with the latest solar, geothermal and biomass technology.

Supplying both domestic and commercial buildings, Altecnic's industry wide reputation for high quality manufacturing and environmental awareness is proven by its certifications ISO 9001:2008, 14001:2004 and OHSAS 18001. Trade merchants, original equipment manufacturers, plumbing and heating engineers and specifiers continue to choose Altecnic's outstanding products and services, fully supported by the national sales team and experienced technical and quality departments.



Please note

WRAS Approved Products
Details of the range of products approved can be found in the Water Fittings and Materials online directory:
www.wras.co.uk



Contact us



General:	01785 218200
Accounts Enquiries:	01785 218203
Technical helpline:	01785 218206
Customer Care Line:	01785 218207
Trade Sales:	01785 218222 tradesales@altecnic.co.uk
OEM Sales:	01785 218208 oemsales@altecnic.co.uk
Specifications Sales:	01785 218210 specifications@altecnic.co.uk



Altecnic Ltd
Mustang Drive, Stafford, Staffordshire ST16 1GW



For thirty years, Altecnic has supported the UK plumbing and heating industry with the best advice and market leading products from our parent company Caleffi S.p.A.

Caleffi was founded in 1961 to provide high quality heating and plumbing components.

Based near Milan in Northern Italy, Caleffi has maintained its principles and grown rapidly to include global sales based out of three core factories within ten miles of Milan.

Caleffi is the largest manufacturer of hydronic components in Italy and from these factories produces stamped brass and thermo plastics, core materials for its ranges, ensuring the very highest quality control.

Recent milestones include:

- 2000 - Caleffi has 600 employees and turnover of 200bn Lira.
- 2002 - Altecnic becomes part of the Caleffi family.
- 2003 - Caleffi introduces market leading separators and deaerators.
- 2007 - Offices open in USA.
- 2008 - The iconic CUBOROSSO research and testing facility is completed. Caleffi has always had a comprehensive quality control process but the CUBOROSSO is it's heart.
- 2010 - An innovative vertical warehouse is built to provide global stock support enabling fast delivery wherever you are.
- 2010 - Japanese offices open.
- 2016 - Caleffi has more than 1,000 employees in 12 companies and over 70 active markets.
- 2018 - Caleffi group consolidated turnover exceeds 350 million euros.
- 2019 - Altecnic strengthens links with Caleffi group

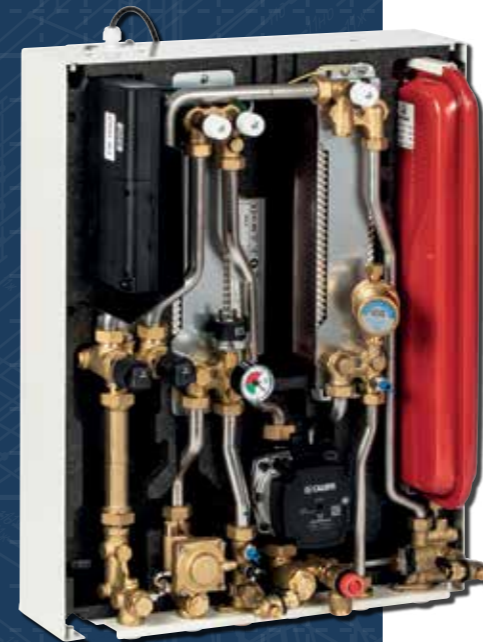

Contents

Heat Interface Units

- 12 **Heat Interface Units**
- 18 Domestic Hot Water Only Heat Interface Units
- 20 HIU Accessories

Plurimod

- 22 **Plurimod Consumer Modules**

Metering

- 23 **Metering**
- 23 Energy Meters
- 25 Water Meters
- 25 Remote Meter Station

Buffer Vessels

- 26 **Buffer Vessels**

Data-logging

- 27 **Data-logging, Modems and Prepayment**

Heat networks

Efficient, reliable and compact, the next generation of SmartSat® intelligent heat interface units for central plant systems.

The drive to conserve finite fossil energy stores and reduce the carbon footprint of buildings to meet latest regulations, has pushed the modern building services engineer to create specific central plant designs.

This allows for the easy and efficient integration of renewable energy sources, such as CHP, solar, heat pumps etc. A central plant system needs to offer a reliable and efficient way of producing hot water, controlling the heating and metering of each individual flat, apartment or house. Altecnic's range of SmartSat® Heat Interface Units (HIUs), consumer modules and metering products, do just that.

The extensive range, includes products for systems with centralised domestic water storage, instantaneous apartment based domestic water generation and apartment based combined cylinders and exchange units.

The latest SmartSat® intelligent heat interface units, the SATK range, take apartment heat interface units to the next level. Utilising electronic control, it enables many significant features not found on other units, for example, modulating primary heating circuit flow temperatures on both direct and indirect heating versions, return temperature limitation, primary flow rate limitation, remote Modbus control, configurable preheat, remote unit isolation, via the internet and a safety pump bypass. Their compact size and insulated enclosure mean that they're easy to locate and extremely efficient.

Each SmartSat® HIU can be installed with a variety of energy meters, all MID approved and capable of communicating by MBus or radio for remote data collection and billing. Altecnic also offers a PLURIMOD consumer unit or apartment control module and remote metering module, intended for installation outside of the apartment and containing all the necessary meters, strainers and isolation equipment required to monitor and control individual apartments.

Altecnic can provide a range of CIBSE approved Continued Professional Development (CPD) seminars on District Heating and other topics.

For further information please contact us.



UK standard for Heat Interface Units

The UK test standard for Heat Interface Units, developed to assess UK heat network operating parameters, is regarded as an important step towards improving the overall performance of British district heating schemes.

Established as part of a UK government research project into heat network efficiency, the standard was, and continues to be, developed under the auspices of a steering group of industry experts and is implemented by the British Engineering Services Association (BESA). Altecnic's electronic SATK32 heat interface unit (HIU) has passed the BESA test.

One of the biggest drivers in the UK heating market is a move towards low carbon building services. Both Altecnic

and our parent company Caleffi pride ourselves on our ability to anticipate market needs and develop innovative products to meet those needs. The electronic SATK32 HIU is a great example of such innovation, with a number of features to help the specifier and end user achieve a cost effective, energy efficient and reliable district heating system.

For more information about Altecnic's SATK32 HIU or CIBSE approved CPD's please contact us.

Altecnic helps construction industry deliver low energy heating

Focusing on new product developments designed specifically for heat pump led networks, Altecnic offer advice on heat networks to maximise low carbon homes.

Updates to the Standard Assessment Procedure (SAP) legislation, SAP10 and 10.1, by The Government due soon will bring significant implications for the construction industry when installing heating systems. To help the industry with the SAP changes relating to carbon output, Altecnic, part of the Caleffi Group, has a team of CIBSE (Chartered Institution of Building Services Engineers) accredited heat network consultants who advise on how to maximise efficiency and ensure compliance.

As a result of changes to the SAP regulation, low temperature heat networks delivered by heat pumps are fast becoming an integral part of the heating mix. This is due to the significant gains in heat network efficiency that they deliver, whether that be from a ground or air source.

To maximise and maintain these efficiencies, it's essential that the heat network includes heat interface units that are designed specifically for this use, such as Altecnic's award-winning* SATK32106 and SATK32107 Heat Interface Units (HIUs).

The Caleffi Group has invested significantly in the R&D of its HIU product range and as a result has further developed its range to increase efficiency and the unit's ability to output an increased temperature range. In addition, Altecnic's specification and technical teams include a number of CIBSE accredited Heat Network Consultants, who can give qualified advice to the industry on the design of heat networks to maximise efficiency and minimise carbon output.

Neil Parry, Head of Specification at Altecnic, said: "Heat networks allow easy integration of various low carbon heat sources. The new heat pump low temperature networks

can be a real win win for all those involved, as well as the environment. But these goals are only achievable with the correct selection of components designed for these networks.

"Here at Altecnic, we want to do more than just provide products to the construction industry. Our team of CIBSE accredited Heat Network Consultants can assess the heating needs of a building and advise on the best way to design the low temperature heat network to maximise efficiencies for the energy source, network, installer and the end user, whilst maintaining compliance."

Low temperature heat networks and how to overcome common problems with heat networks is a topic that Neil will be talking about at the CIBSE Build 2 Perform conference in London on 26th and 27th November.

Altecnic Ltd is the UK's leading supplier of hydronic solutions. Established near Stafford in 1987, the company imports and supplies over 5,000 product lines to distributors throughout the UK and Republic of Ireland. The company provides trade merchants, plumbing and heating engineers and specifiers with a comprehensive range of plumbing products, including: thermostatic mixing valves, underfloor heating, sealed systems, dirt and air separation, backflow prevention and vessels and a whole lot more.

Altecnic's mission statement is to deliver the highest quality products and services to its customers, through manufacturing excellence, innovation and education. Their extensive range of products and services are chosen by trade merchants, original equipment manufacturers, plumbing and heating engineers and specifiers.

IMAGES?

CASE STUDY: CAROLYN HOUSE



Altecnic Ensures Energy Efficient District Heating System for New London Apartments

A new apartment block that has been converted from offices will benefit from an energy efficient district heating system thanks to 183 Heat Interface Units (HIUs) and more than 800 dynamic thermostatic radiator valves (TRVs) from Altecnic.

M&E contractors G&H Group worked closely with Altecnic to develop the specification for Carolyn House following its change of use from offices to an apartment block. The specification and correct installation of the central heating system will save future residents money and also ensure that every apartment has a reliable source of hot water and heating, even at times of peak demand.

Says David Davis, Group Director for G&H "District heating systems such as this are becoming more common and we were keen to work closely with a manufacturer who not only supplies product but also provides technical advice and training so that we could provide an efficient and reliable solution."

Achieving maximum efficiency from such a system relies on the HIU in each apartment returning a very low temperature back onto the network. This keeps primary flow rates low, reduces heat lost from the system, ensures the greatest benefit from any included renewable energy sources and allows condensing boilers to work at their optimum efficiency.

The low heating demand in modern apartments means that only a very small flow rate of hot water is required on the space heating circuit. This low flow rate makes it difficult to balance the radiators, so there is a danger of a high space heating return temperature being passed back onto the network. This reduces the efficiency of the whole network.

Working closely with Altecnic, G&H maximised the difference in temperature between the flow and return temperatures (Delta T) on each apartment's space heating circuits.

specification for Carolyn House following its change of use from offices to an apartment block. The specification and correct installation of the central heating system will save future residents money and also ensure that every apartment has a reliable source of hot water and heating, even at times of peak demand.

Says David Davis, Group Director for G&H "District heating systems such as this are becoming more common and we were keen to work closely with a manufacturer who not only supplies product but also provides technical advice and training so that we could provide an efficient and reliable solution."

Achieving maximum efficiency from such a system relies on the HIU in each apartment returning a very low temperature back onto the network. This keeps primary flow rates low, reduces heat lost from the system, ensures the greatest benefit from any included renewable energy sources and allows condensing boilers to work at their optimum efficiency.

"Working closely with Altecnic, G&H maximised the difference in temperature between the flow and return temperatures on each apartment's space heating circuits."

G&H Group

The low heating demand in modern apartments means that only a very small flow rate of hot water is required on the space heating circuit. This low flow rate makes it difficult to balance the radiators, so there is a danger of a high space heating return temperature being passed back onto the network. This reduces the efficiency of the whole network.

Working closely with Altecnic, G&H maximised the difference in temperature between the flow and return temperatures (Delta T) on each apartment's space heating circuits.

First using the Dynamical TRVs from Altecnic, it is possible to pre-set the maximum allowable flow rate for each radiator on the Dynamical valve before installation. Once installed,



the valve finely controls the flow rate of water through each radiator regardless of changes in pressure on the space heating circuit. This ensures that the required flow is never exceeded, the maximum heat output from the radiator is maximised and the subsequent return temperature to the HIU is kept low.

Second the SATK32103 HIUs are equipped with Return Temperature Limitation (RTL). This allows a maximum return temperature back onto the network to be set. Once enabled and set, the HIU will control its output into the apartment to ensure that the pre-set primary return temperature is met. Not only does this mean that each apartment is efficiently heated for minimum cost to each resident, but it ensures that the overall network is efficient and protected from failure due to small Delta T's and high primary flow rates.

The lower return temperature also means that the heat network size can be reduced and a lot less energy is lost into the building fabric. Well designed heat networks, pre-settable dynamic radiator valves and RTL within HIU's will result in more efficient networks and greatly reduce the potential for overly warm corridors during the warmer months.

Continues Davis, "I know that other contractors have had problems with district heating systems in the past due to the nature of commissioning such systems. We wanted to partner with a supplier that could work with us to develop the specification and provide product and training to ensure that the scheme is successfully commissioned. Every resident in this apartment block will get heating and hot water on demand even at times of peak usage, such as on a Monday morning before people go to work.

"Altecnic's HIUs and TRVs and their level of technical advice and assistance have been invaluable in this very successful project."

HEAT INTERFACE UNITS - INDIRECT



ALT-SATK32103

SATK32 INDIRECT WITH NETWORK PROTECTION AND INTEGRAL ROOM CONTROLLER

Ref. no	Description
ALT-SATK32103	Indirect SATK32103 HIU with filling loop pack (50kW DHW)
ALT-SATK32105	Indirect SATK32105 HIU with filling loop pack (75kW DHW)
ALT-SATK32106	Indirect HIU designed specifically for low temperature, heat pump led networks
ALT-SATK32107	Indirect HIU designed specifically for low temperature, heat pump led networks

SPECIFICATION

- Electronic control
- Up to 50 or 75kW DHW output
- Up to 15kW heating output
- Primary return temperature limitation
- Primary flow rate limitation
- User configurable preheat
- Modbus output
- Full clamshell insulation
- 600 kPa differential pressure capability
- Pump anti-clog feature
- Dimensions (H x W x D) 630 x 490 x 250mm*

* Including front cover

Please note: all above items are available with a choice of various specification energy meter. See Metering pages for details.



ALT-SATK32103

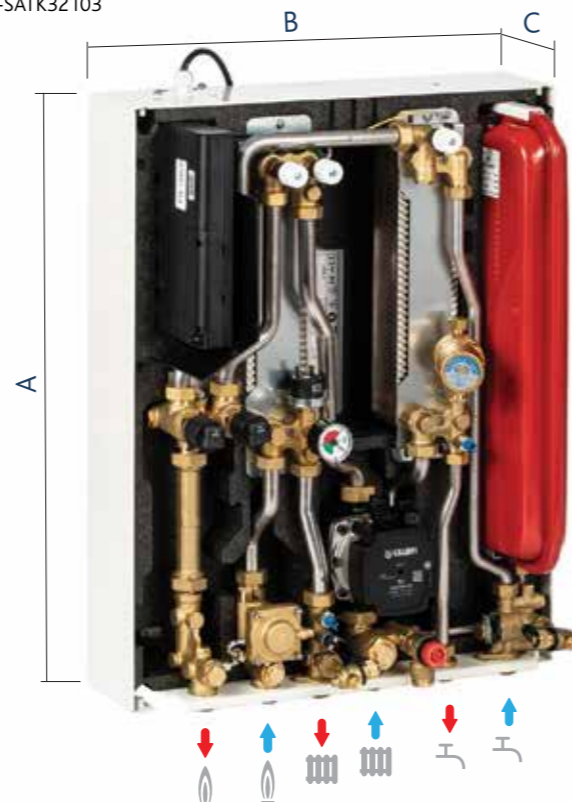

Ref. no	All Connections	A	B	C (Depth inc. Cover)	kg
ALT-SATK32103	G3/4B	630	490	250	34
ALT-SATK32105	G3/4B	630	490	250	35

HEAT INTERFACE UNITS - INDIRECT



ALT-SATK30103



ALT-SATK30105



202-1004

SATK30 INDIRECT

Ref. no	Description
ALT-SATK30103	Indirect SATK30103 HIU with filling loop pack (50kW DHW)
ALT-SATK30105	Indirect SATK30105 HIU with filling loop pack (75kW DHW)

SPECIFICATION



- Electronic control
- Up to 50 or 75kW DHW output
- Up to 15 kW heating output
- Radiator or UFH temperatures
- Includes pump bypass in case of complete TRV shutdown
- Optional automatic flow temperature control based on heating return temperatures
- Pump anti-clog feature
- Heating circuit safety pressure sensor
- Lockable, insulated cover
- Digital commissioning
- Intelligent primary bypass
- Stainless steel pipework
- Dimensions (H x W x D) 630 x 550 x 265mm

Please note: all above items are available with a choice of various specification energy meter. See Metering pages for details.

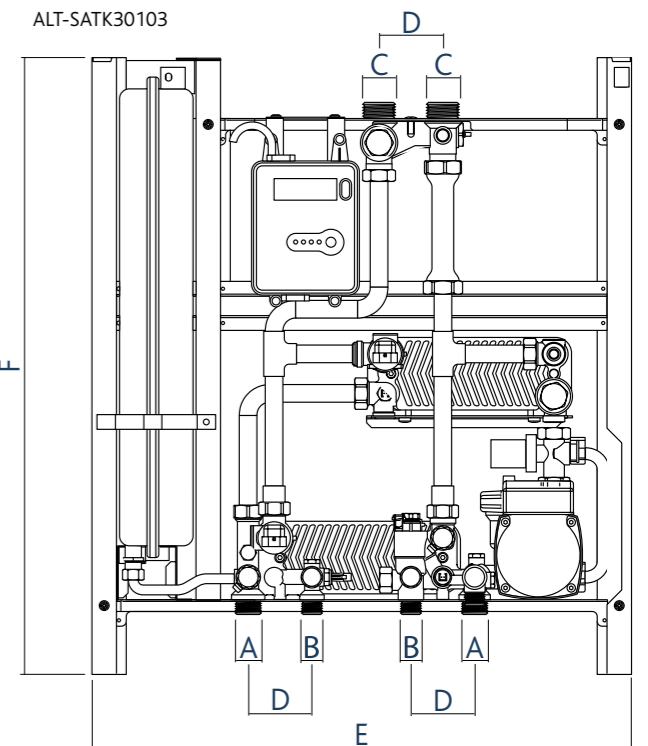

Double Award Winner



Connection	A	B	C	D	E	F	Depth inc. Cover	kg
Thread	G3/4B	G1/2B	G1B	65	550	630	265	19

HEAT INTERFACE UNITS - INDIRECT



ALT-SATK60103

SATK60 INDIRECT, FLUSH IN WALL MOUNTED

Ref. no	Description
ALT-SATK60103	Indirect SATK30103 HIU with filling loop pack (50kW DHW)

SPECIFICATION



- Electronic control
- Up to 50kW DHW output
- Up to 15kW heating output
- Radiator or UFH temperatures
- Includes pump bypass in case of complete TRV shutdown
- Optional automatic flow temperature control based on heating return temperatures
- Pump anti-clog feature
- Heating circuit safety pressure sensor
- Lockable, insulated cover
- Digital commissioning
- Intelligent primary bypass
- Stainless steel pipework
- Dimensions (H x W x D) 890 x 625 x 140mm

Please note: all above items are available with a choice of various specification energy meter. See Metering pages for details.

ALT-SATK60103

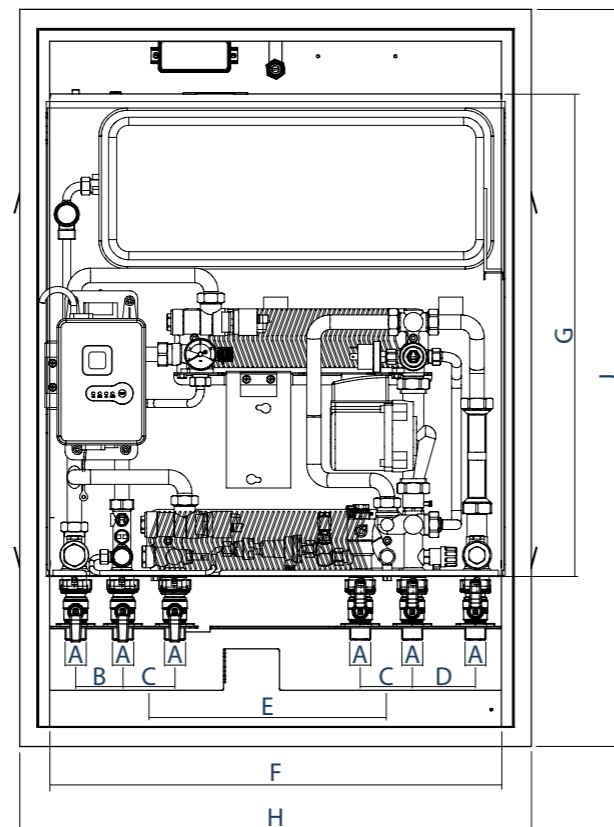

A	B	C	D	E	F	G	H	J
G1B	59	65	79	232	570	590	625	890

HEAT INTERFACE UNITS - DIRECT



ALT-SATK20303



ALT-SATK20103



202-1003



Double Award Winner



SATK20 DIRECT

Ref. no	Description
ALT-SATK20103	Low temperature, direct SATK20103 HIU with DPCV
ALT-SATK20203*	Medium temperature, direct SATK20203 HIU with DPCV
ALT-SATK20303*	High temperature, direct SATK20303 HIU with DPCV
ALT-SATK20403	High temperature, Pumped, direct SATK20403 HIU with DPCV

SPECIFICATION



- Electronic control
- Up to 50 kW DHW output
- Up to 15 kW heating output
- Modulating or fixed heating flow temperatures
- Suitable for UFH without additional mixing circuit (SATK20103)
- Low, medium and high temperature models available
- Includes pump bypass in case of complete TRV shutdown
- Optional heating pump
- Lockable, insulated cover with meter window. Metal, powder coated insulated cover also available
- Stainless steel pipework
- Integral heating circuit DPCV
- Dimensions (H x W x D) 550 x 450 x 265mm

Please note: all above items are available with a choice of various specification energy meter. See Metering pages for details.

ALT-SATK20103

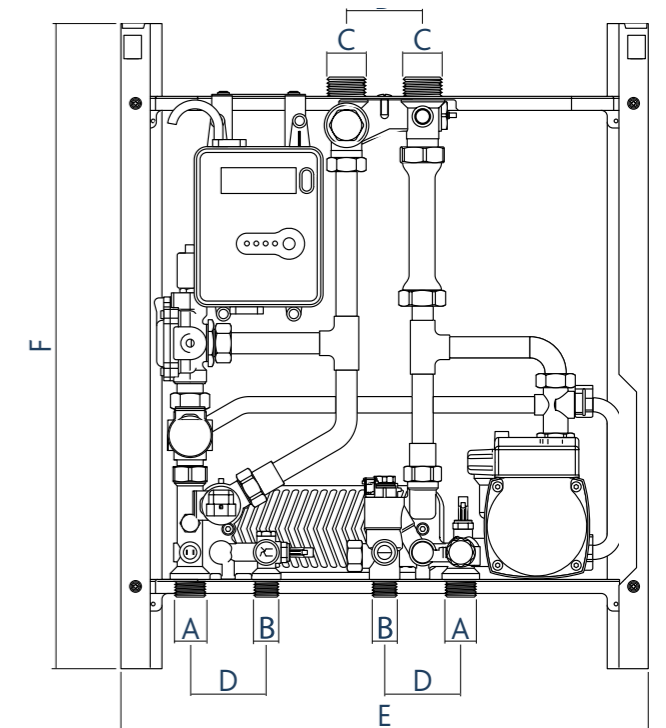

Connection	A	B	C	D	E	F	Depth inc. Cover	kg
Thread	G3/4B	G1/2B	G1B	65	450	550	265	16

HEAT INTERFACE UNITS - DIRECT



ALT-SATK50303

SATK50 DIRECT, FLUSH IN WALL MOUNTED

Ref. no	Description
ALT-SATK50103	Low temperature, direct SATK20103 HIU with DPCV
ALT-SATK50203*	Medium temperature, direct SATK20203 HIU with DPCV
ALT-SATK50303*	High temperature, direct SATK20303 HIU with DPCV
ALT-SATK50403	High temperature, Pumped, direct SATK20403 HIU with DPCV

SPECIFICATION



- Electronic control
- Up to 50 kW DHW output
- Up to 15 kW heating output
- Modulating or fixed heating flow temperatures
- Suitable for UFH without additional mixing circuit (SATK50103)
- Low, medium and high temperature models available
- Includes pump bypass in case of complete TRV shutdown
- Optional heating pump
- Lockable, insulated cover with meter window. Metal, powder coated insulated cover also available
- Stainless steel pipework
- Optional heating circuit DPCV
- Dimensions (H x W x D) 700 x 600 x 120mm

Please note: all above items are available with a choice of various specification energy meter. See Metering pages for details.

ALT-SATK50103

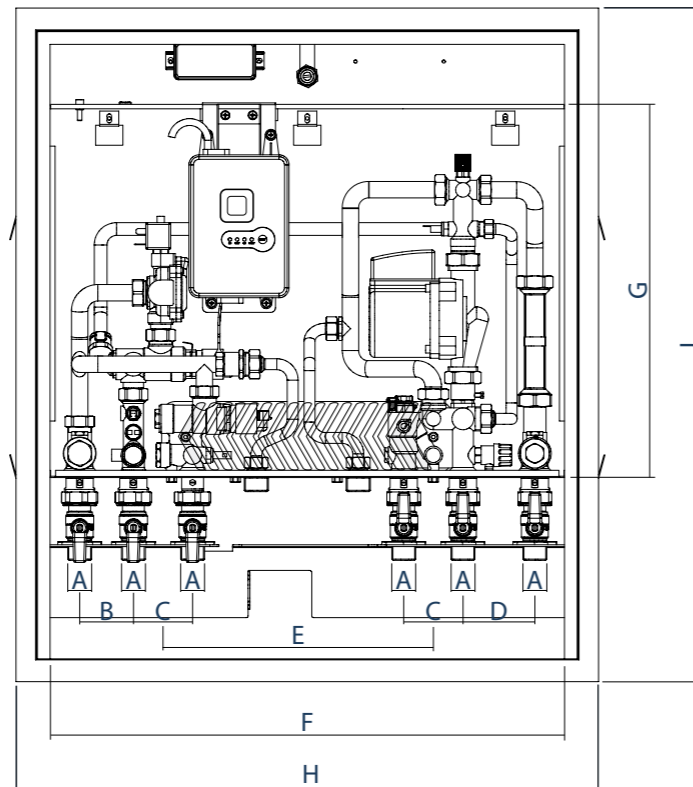

A	B	C	D	E	F	G	H	J
G1B	59	65	79	232	570	410	600	700

HEAT INTERFACE UNITS - STORED HOT WATER

PROCYL COMBINED HIU AND STORAGE CYLINDER

Ref. no	Description
ProCyl90	Combined HIU and cylinder, electronic control, 90 litre capacity with 15kW heating
ProCyl150	Combined HIU and cylinder, electronic control, 150 litre capacity with 15kW heating
ProCyl200	Combined HIU and cylinder, electronic control, 200 litre capacity with 15kW heating



SPECIFICATION

- Electronically controlled heat interface unit with integral cylinder
- Indirect heating up to 15kW
- 90, 150, & 200 litre integral cylinder sizes
- Lockable, insulated HIU cover with tenant meter window
- Includes inlet control group, expansion vessel and safety relief valve
- Fully shrouded cylinder and frame
- Integral immersion heater

Please note: all above items are available with a choice of various specification energy meter. See Metering pages for details.

SATK40 INDIRECT

Ref. no	Description
ALT-SATK40103	SATK40103 HIU with filling loop pack

SPECIFICATION

- Electronically controlled heat interface unit
- Indirect heating, up to 15kW
- Suitable for connection to an indirect hot water cylinder
- Up to 50kW DHW capacity (configurable)

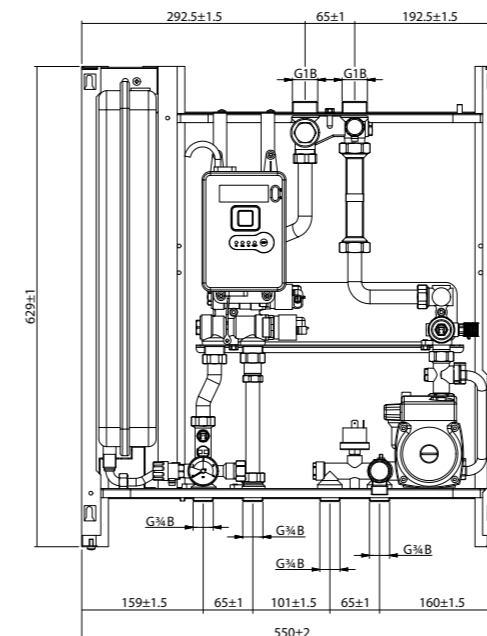

Please note: all above items are available with a choice of various specification energy meter. See Metering pages for details.

HEAT INTERFACE UNITS - HOT WATER ONLY

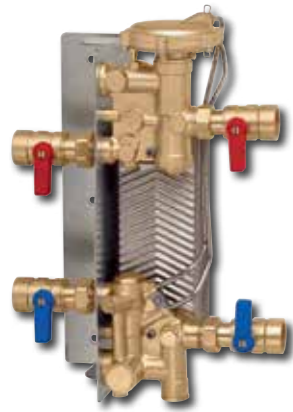

SATK101

Ref. no	Description
ALT-SATK101	DHW only HIU, mechanical control, 35kW DHW

SPECIFICATION

- Wall-mounted
- Up to 35 kW DHW output
- Optional primary differential pressure control valve
- Optional energy meter
- Dimensions (H x W x D) 355 x 175 x 150mm

SATK102

Ref. no	Description
ALT-SATK10203	DHW only HIU, electronic control, 40kW DHW with pump
ALT-SATK10253	DHW only HIU, electronic control, 40kW DHW without pump
ALT-SATK10204	DHW only HIU, electronic control, 70kW DHW with pump
ALT-SATK10254	DHW only HIU, electronic control, 70kW DHW without pump
ALT-SATK10205	DHW only HIU, electronic control, 80kW DHW with pump
ALT-SATK10255	DHW only HIU, electronic control, 80kW DHW without pump

SPECIFICATION

- Wall-mounted
- Electronic control
- Up to 40 / 70 / 80 kW DHW output
- Optional primary support pump
- 2-way primary modulating valve
- Settable DHW temperature
- Includes cover
- Can be grouped for higher DHW outputs, using the cascade controller
- Dimensions (H x W x D) 330 x 420 x 235mm



HEAT INTERFACE UNITS

APARTMENT CONTROL MODULE

Ref. no	Description
799252LTC	Tenant interface module for heating and cylinder connection
201-1002	Landlord control pack

SPECIFICATION

- Tenant distribution module
- For heating and indirect hot water cylinders
- 'Non plate' design with a common return
- Two Integral two port motorised valves and wiring centre
- Integral DPCV
- Integral isolation valves and strainer
- Optional landlord shut off valve
- Optional energy meter
- Dimensions (H x W x D) 600 x 400 x 185mm

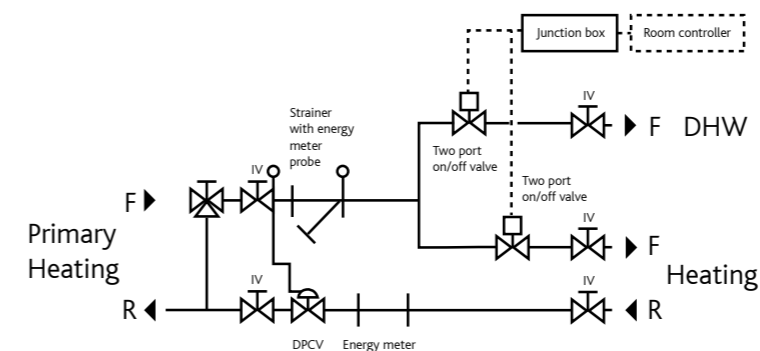
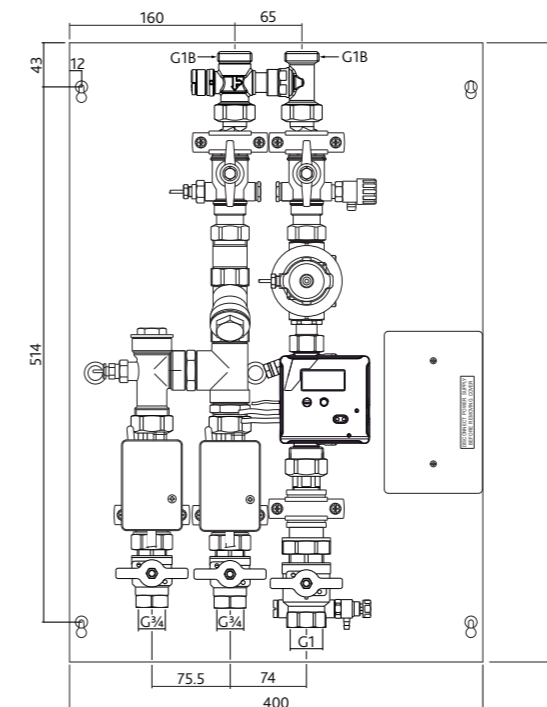

HIU ACCESSORIES

TWO ZONE HEATING PACK FOR ALL HIU MODELS

Ref. no	Description
202-1001	Flow manifold heating pack
202-1002	Return manifold heating pack

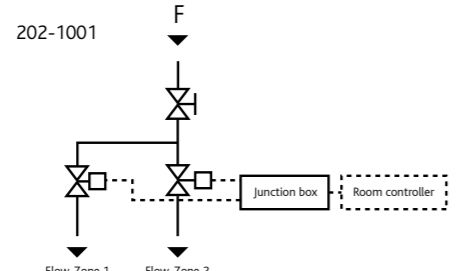
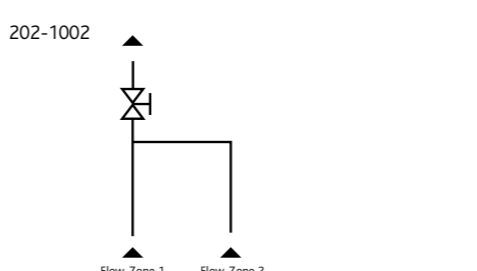
DIGITAL PROGRAMMABLE ROOM CONTROLLERS

Ref. no	Description
501-0007	Digital programmable room thermostat - wired
501-0006	Digital programmable room thermostat - wireless

SPECIFICATION

- Power supply 3V - 2x1.5AA alkaline
- LCD 3" display
- 1 potential-free changeover contact output: 8(2)A/250Va.c.
- ON/OFF operation with adjustable differential switch 0.2 - 2°C
- 5 pre-set programs + 1 free
- Temperature levels 3 + anti-freeze
- Temperature adjustable by 0.5°C sets
- Consumption counter
- Minimum programming 30 minutes
- Temporary/permanent manual operation
- system irregularity signalling
- Interruption button for cleaning operations
- Telephone control input
- Intelligent operation
- SUM/WIN control
- Holiday program
- Pump activation program
- Temperature setting lock
- Dimensions (LxWxH) 120 x 27.6 x 82



Please note: image used for illustration purposes only and unit supplied may differ in appearance.

HEAT NETWORK BYPASS ASSEMBLY

Ref. no	Description
TBA	Heat network bypass valve assembly, 3/4", 10-60kPa and automatic balancing valve (flow rate to be selected) inc' isolation
TBA	Heat network bypass valve assembly, 1 1/4" 10-60kPa and automatic balancing valve (flow rate to be selected) inc' isolation
TBA	Heat network bypass valve assembly, 3/4", 100-400kPa and automatic balancing valve (flow rate to be selected) inc' isolation

SPECIFICATION

- Heat network bypass assembly
- Avoids wasted energy use and assists in holding low return temperatures
- Adjustable differential pressure bypass valve
- Autoflow, automatic balancing valve (flow rate to be selected)
- Including isolation valves
- Can be used on phased projects to ensure flexible bypass control



HIU ACCESSORIES

FIRST FIX MOUNTING RAIL

Ref. no	Description
789020	First fix mounting rail for SATK20
789030	First fix mounting rail for SATK30

SPECIFICATION

- First fix mounting rail for the SATK20 and SATK30 HIU's
- Includes isolation valves and air vents
- Stainless steel pipework
- Makes all pipework bottom entry



'H' PATTERN FLUSHING BYPASS

Ref. no	Description
789100	Primary flushing bypass to suit SATK20 and 30

SPECIFICATION

- 'H' pattern flushing bypass
- Three-port valve to open or isolate the bypass
- For use with straight pattern isolation valves (included with HIU)



COLD WATER CONNECTION KIT

Ref. no	Description
794540	Cold water connection kit with water meter spacer piece for SATK20 and 30

SPECIFICATION

- Cold water meter pipework
- Integral isolation valves
- Water meter sold separately (see 'Metering')



HOT WATER RECIRCULATION AND COLD WATER KIT

Ref. no	Description
794530	Hot water recirculation and cold water connection kit for DHW only HIU's

SPECIFICATION

- Combined cold water meter and hot water recirculation connection
- Integral isolation valves and check valve
- Water meter sold separately (see 'Metering')
- Suitable for DHW only HIU's

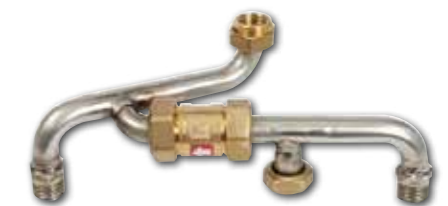

STRAIGHT PATTERN SECONDARY ISOLATION BALL VALVE SET

Ref. no	Description
ALT-BVHIU01	SATK20 ball valve set
ALT-BVHIU03	SATK30 ball valve set



PLURIMOD CONSUMER MODULES



7000 SERIES UNIVERSAL MODULE

Ref. no	Description
700105	Plurimod Clima Universal module

SPECIFICATION

- 2-way or 3-way heating operations
- Switchable left or right handed
- Up to three domestic metering outlets for centralised DHW, DCW, grey water ect.
- Heat metering
- DPCV heating control or AUTOFLOW® ABV
- DHW return connection available



70009 SERIES UNIVERSAL MODULE WITH RADIATOR DISTRIBUTION

Ref. no	Description
70009B	70009 (Plurimod, spacer piece for EM, 2 x spacer pieces for WM's, 2 rad zones)
70009C	70009 (Plurimod, spacer piece for EM, 2 x spacer pieces for WM's, 3 rad zones)
70009D	70009 (Plurimod, spacer piece for EM, 2 x spacer pieces for WM's, 4 rad zones)
70009E	70009 (Plurimod, spacer piece for EM, 2 x spacer pieces for WM's, 5 rad zones)
70009F	70009 (Plurimod, spacer piece for EM, 2 x spacer pieces for WM's, 6 rad zones)
70009G	70009 (Plurimod, spacer piece for EM, 2 x spacer pieces for WM's, 7 rad zones)
70009H	70009 (Plurimod, spacer piece for EM, 2 x spacer pieces for WM's, 8 rad zones)

SPECIFICATION

- 2-way or 3-way heating operations
- Switchable left or right handed
- One or two domestic metering outlets DHW, DCW
- Heat metering
- DPCV heating control or AUTOFLOW® ABV
- Radiator distribution manifold
- DHW return connection available



70008 SERIES UNIVERSAL MODULE WITH UNDERFLOOR HEATING DISTRIBUTION

Ref. no	Description
70008B	70008 (Plurimod, spacer piece for EM, 2 x spacer pieces for WM's, 2 UFH zones)
70008C	70008 (Plurimod, spacer piece for EM, 2 x spacer pieces for WM's, 3 UFH zones)
70008D	70008 (Plurimod, spacer piece for EM, 2 x spacer pieces for WM's, 4 UFH zones)
70008E	70008 (Plurimod, spacer piece for EM, 2 x spacer pieces for WM's, 5 UFH zones)
70008F	70008 (Plurimod, spacer piece for EM, 2 x spacer pieces for WM's, 6 UFH zones)
70008G	70008 (Plurimod, spacer piece for EM, 2 x spacer pieces for WM's, 7 UFH zones)

SPECIFICATION

- 2-way or 3-way heating operations
- Switchable left or right handed
- One or two domestic metering outlets DHW, DCW
- Heat metering
- DPCV heating control or AUTOFLOW® ABV
- Radiant panel distribution manifold with optional flow control valves
- DHW return connection available



7000 SERIES DUPLEX MODULE

Ref. no	Description
70075DUP	Duplex (2 x Plurimod, 2 x spacer pieces for EM's, 4 x spacer pieces for WM's)

SPECIFICATION

- Double apartment/user module
- 2-way or 3-way heating operations
- Switchable left or right handed
- Up to six domestic metering outlets
- DPCV heating control or AUTOFLOW® ABV
- Heat metering
- DHW return connection available

METERING

ITRON C F ECHO II ENERGY METER

Ref. no	Size	Power	Output
204-1...	15 - 50mm	- Mains - Battery	- M-Bus - Pulsed - Radio - GPRS - RS232

- Call for details



ITRON COMPACT ENERGY METER - ULTRAMAX

Ref. no	Size	Power	Output
204-2...	15 - 20mm	- Mains - Battery	- M-Bus - Pulsed - Radio

- Call for details



ISTA ULTEGO ENERGY METER

Ref. no	Size	Power	Output
204-3...	15 - 20mm	- Mains - Battery	- M-Bus - Pulsed - Radio

- Call for details



METERING



T230 ENERGY METER

Ref. no	Size	Power	Output
204-5...	15 - 20mm	- Mains - Battery	- M-Bus - Pulsed - Radio

- Call for details



HYDROMETER ENERGY METER

Ref. no	Size	Power	Output
204-6...	15 - 20mm	- Mains - Battery	- M-Bus - Pulsed - Radio - GPRS - RS232

- Call for details



KAMSTRUPP ENERGY METER

Ref. no	Size	Power	Output
204-4...	15 - 20mm	- Mains - Battery	- M-Bus - Pulsed - Radio - GPRS - RS232

- Call for details

Other sizes and specifications of meters are available.

METERING

COLD WATER METERS - PULSED OUTPUT

Ref. no	Description
PS-100001	½" Class D meter/MID R100
PS-100002	¾" Class D meter/MID R100
PS-100003	1" Class D meter/MID R100

SPECIFICATION

- Pulsed output (1 pulse per litre or 1 pulse per 10 litres)
- Supplied with 1M cable
- Other sizes available



HOT WATER METERS - PULSED OUTPUT

Ref. no	Description	Size
GG-USLC13PIO	Hot water meter with pulsed output	½"
GG-USLC20PIO	Hot water meter with pulsed output	¾"
GG-DALC25PIO	Hot water meter with pulsed output	1"

SPECIFICATION

- Suitable for temperatures up to 90 °C
- Pulsed output (1 pulse per litre or 1 pulse per 10 litres)
- Supplied with 1M cable
- Other sizes available



REMOTE METER STATION

Ref. no	Description
Ask for details	Wall mounted metering station for energy
Ask for details	Wall mounted metering station for energy and cold water metering
Ask for details	Wall mounted metering station for energy, cold and hot water metering
Ask for details	Wall mounted metering station for energy, cold, hot and grey water metering

SPECIFICATION

- Flush wall mounted or surface mounted backing plate
- Flexible configuration
- Optional domestic cold water outlet
- External to apartment, metering module
- Optional heat and cold water meter
- Optional strainers
- M-Bus & RF energy meter options



BUFFER VESSELS



PLANT-ROOM BUFFER VESSELS

Ref. no	Description	Size (litre)
HV1000Y	LTHW buffer vessel	1000
HV1500Y	LTHW buffer vessel	1500
HV2000Y	LTHW buffer vessel	2000
HV2500Y	LTHW buffer vessel	2500

SPECIFICATION

- 1000 to 2500 litre vessels include insulation as standard



Ref. no	Description	Size (litre)
HV3000Y	LTHW buffer vessel	3000
HV4000Y	LTHW buffer vessel	4000
HV5000Y	LTHW buffer vessel	5000

SPECIFICATION

- For LTHW storage
- Maximum operating pressure 6 bar
- Maximum operating temperature 95 °C
- Red, powder coated exterior

BUFFER VESSEL INSULATION

Ref. no	Description
HVA3000A	3000 litre vessel insulation
HVA4000A	4000 litre vessel insulation
HVA5000A	5000 litre vessel insulation

SPECIFICATION

- Thermal insulation to suit the buffer vessels
- 90mm thick, 'soft' PU insulation
- Includes white PUF foil coat

DATA-LOGGING, MODEMS AND PREPAYMENT

DATA CONCENTRATOR

Ref. no	Description
205-1003	Suitable for up to 128 energy meters
205-1004	Suitable for up to 256 energy meters

SPECIFICATION

- 128 and 256 meters
- Extendable network up to 1000 meters
- Local data reading via USB/RS232
- Can be easily upgraded with an infra-red GPRS modem for remote meter reading



GPRS MODEM

Ref. no	Description
204-7010	GPRS modem

SPECIFICATION

- GPRS modem
- Automatically sends meter usage data via email or text message
- Requires sim card
- Optional mounting box available on request



PREPAYMENT SYSTEM WITH A DEDICATED CONTROL UNIT, INDEPENDENT TENANT DISPLAY FOR EASY INSTALLATION

Ref. no	Description
205-1001	Pre-payment system

SPECIFICATION

- Secure credit management for landlords
- Smarter budgeting and payment options for tenants
- Graphical and easy to read tenant screen, is connected wirelessly to the prepayment unit. This screen can be located conveniently within the apartment for the tenant to better manage their balance and account.
- Secure online payment portal for the tenant to top-up with credit or debit cards and local top-up facilities with PayPoint 26,700 retail points across the country
- Wireless Smart metering of heat and hot water, avoiding the need for cabling and building M-Bus systems for data collection. The screen can provide a messaging capability to each tenant; events, key dates, marketing opportunities.
- The system is remote changeable between a prepayment and traditional credit system.
- The system is compliant with ENE3 Code for Sustainable Homes



General information

Office hours:

Monday to Friday 8.30am - 5.00pm.

Prices:

Prices are exclusive of VAT and are subject to change without notice.

All prices displayed are recognised as list.

Terms:

A copy of Altecnic's terms and conditions is available on request.

Property of goods:

Until full payment has been received, all goods supplied remain the property of Altecnic Ltd.

Delivery:

Carriage paid 3 day service, UK mainland only. (minimum order value of £100 applies or £7.50 small order charge applies)

Aftersales Support

We have extensive stocks of spares for both current and previous HIU models. All spares are available via our distribution network consisting of over 3000 suppliers across the UK. We have both office and geographically based technical and service teams ready to assist with all servicing and technical queries and on-site attendance if required. Please call 01785 218 206 to reach our technical support team.

Customer care notice

Full details of Altecnic's Returns Policy are available at www.altecnic.co.uk

Useful contacts

Accounts enquiries: 01785 218203

Customer care line: 01785 218207

Sales: 01785 218210

specifications@altecnic.co.uk



Altecnic Ltd - CALEFFI group

Mustang Drive, Stafford, Staffordshire ST16 1GW

T: 01785 218210 F: 01785 218201 E: specifications@altecnic.co.uk

Registered in England No: 2095101

altecnic.co.uk

© Patents & Design Altecnic 2019

Altecnic Ltd retains all rights (including patents, designs and copyrights, trademarks and any other intellectual property rights) in relation to all information provided on or via the website, brochures or any other documents, including all texts, graphics and logos, contained on the website, in brochures or in any other documents published in the name of or on behalf of Altecnic Ltd in any form, without prior written consent of Altecnic Ltd.